



中国认可
国际互认
检测
TESTING
CNAS L7472



APPLICATION FOR ELECTROMAGNETIC COMPATIBILITY DIRECTIVE

On Behalf of

SMISS Technology Co.,Ltd.

Disposable electronic cigarette

Model No.: 77777

Prepared for : SMISS Technology Co.,Ltd.
Address : Building 3, Mingwei Industrial Park, No. 1, Songgang Avenue, Baoan District
Shenzhen. China 518105

Prepared By : Shenzhen Alpha Product Testing Co., Ltd.
Address : Building i, No.2, Lixin Road, Fuyong Street, Bao'an District, 518103, Shenzhen,
Guangdong, China

Report Number : A2401256-C01-R01
Date of Receipt : January 30, 2024
Date of Test : January 30, 2024
Date of Report : February 1, 2024
Version Number : V0
Test Result : Pass

ALPHA's reports is using a digital certificate that is trusted on Adobe's official server. If there is no digital certificate or the digital certificate shows damaged in your report. Please do not accept the report.

E-mail: service@a-lab.cn Tel: 4008-3008-95 Website: <http://www.a-lab.cn>

TABLE OF CONTENTS

Description	Page
1. Summary Of Standards And Results	7
1.1. Description of Standards and Results	7
2. General Information	8
2.1. Description of Device (EUT)	8
2.2. Accessories of Device (EUT)	8
2.3. Tested Supporting System Details	9
2.4. Block Diagram of connection between EUT and simulators	9
2.5. Test mode Description	10
2.6. Test Facility	11
2.7. Measurement Uncertainty	11
2.8. Test Equipment	12
2.9. Classification Of Apparatus Description	15
3. Conducted Disturbance At Mains Terminals Test	16
3.1. Block Diagram of Test Setup	16
3.2. Power Line Conducted Emission Test Limits	16
3.3. Configuration of EUT on Test	16
3.4. Operating Condition of EUT	16
3.5. Test Procedure	17
3.6. Conducted Disturbance at Mains Terminals Test Results	18
4. Disturbance Power Test	21
4.1. Block Diagram of Test Setup	21
4.2. Disturbance Power Test Limits	21
4.3. Configuration of EUT on Test	21
4.4. Operating Condition of EUT	21
4.5. Test Procedure	22
4.6. Disturbance Power Test Results	23
5. Radiated Disturbance Test	24
5.1. Block Diagram of Test Setup	24
5.2. Radiated Emission Limit	25
5.3. Configuration of EUT on Test	25
5.4. Operating Condition of EUT	25
5.5. Test Procedure	25
5.6. Radiated Disturbance Test Results	26
6. Clicks	29
7. Harmonic Current Test	30
7.1. Block Diagram of Test Setup	30
7.2. Harmonic Current Test Limits	30
7.3. Configuration of EUT on Test	31
7.4. Operating Condition of EUT	31
7.5. Test Procedure	31
7.6. Harmonic Current Test Results	32

8. Voltage Fluctuations & Flicker Test	33
8.1. Block Diagram of Test Setup	33
8.2. Voltage Fluctuation and Flicker Test Limits	33
8.3. Configuration of EUT on Test	33
8.4. Operating Condition of EUT	33
8.5. Test Procedure	33
8.6. Voltage Fluctuation and Flicker Test Results	34
9. Immunity Performance Criteria	35
10. Electrostatic Discharge Test	36
10.1. Block Diagram of Test Setup	36
10.2. Electrostatic Discharge Test Limits	36
10.3. Configuration of EUT on Test	36
10.4. Operating Condition of EUT	36
10.5. Test Procedure	37
10.6. Electrostatic Discharge Test Results	38
11. RF Field Strength Susceptibility Test	39
11.1. Block Diagram of Test Setup	39
11.2. RF Field Strength susceptibility Test Limits.....	39
11.3. Configuration of EUT on Test	39
11.4. Operating Condition of EUT	39
11.5. Test Procedure	40
11.6. RF Field Strength Susceptibility Test Results	41
12. Electrical Fast Transient/Burst immunity Test	42
12.1. Block Diagram of Test Setup	42
12.2. Test Standard	42
12.3. Electrical Fast Transient/Burst Test Limits	42
12.4. Configuration of EUT on Test	42
12.5. Operating Condition of EUT	42
12.6. Test Procedure	43
12.7. Electrical Fast Transient/Burst immunity Test Results	44
13. SURGE Test	45
13.1. Block Diagram of Test Setup	45
13.2. Surge Test Limits.....	45
13.3. Configuration of EUT on Test	45
13.4. Operating Condition of EUT	45
13.5. Test Procedure	46
13.6. Surge Test Results	47
14. Injected currents susceptibility test	48
14.1. Block Diagram of Test Setup	48
14.2. Test Standard	48
14.3. Injected currents susceptibility Test Limits	48
14.4. Configuration of EUT on Test	48
14.5. Operating Condition of EUT	49
14.6. Test Procedure	49
14.7. Injected currents susceptibility Test Results.....	50

15. Voltage dips and interruptions test.....	51
15.1. Block Diagram of Test Setup	51
15.2. Test Standard	51
15.3. Voltage dips and interruptions Test Limits.....	51
15.4. Configuration of EUT on Test	51
15.5. Operating Condition of EUT	51
15.6. Test Procedure	51
15.7. Voltage dips and interruptions Test Results	52
16. Photograph	53
16.1. Photo of Radiated Disturbance Test.....	53
16.2. Photos Of Power Line Conducted Emission Test	53
16.3. Photos of Electrostatic Discharge Test.....	54
16.4. Photo of RF Field Strength Susceptibility Test	54
17. Photos Of The EUT	55

TEST REPORT DECLARATION

Applicant : SMISS Technology Co.,Ltd.
 Address : Building 3, Mingwei Industrial Park, No. 1, Songgang Avenue, BaoanDistrict
 Shenzhen. China 518105
 Manufacturer : SMISS Technology Co.,Ltd.
 Address : Building 3, Mingwei Industrial Park, No. 1, Songgang Avenue, BaoanDistrict
 Shenzhen. China 518105
 EUT Description : Disposable electronic cigarette
 (A) Model No. : 77777
 (B) Trademark : Abu Rashed

Measurement Standard Used:

EN IEC 55014-1:2021

EN IEC 55014-2:2021

The device described above is tested by Shenzhen Alpha Product Testing Co., Ltd. to determine the maximum emission levels emanating from the device and the severe levels of the device can endure and its performance criterion. The test results are contained in this test report and Shenzhen Alpha Product Testing Co., Ltd. is assumed full responsibility for the accuracy and completeness of test. Also, this report shows that the EUT is technically compliant with the EN IEC 55014-1 and EN IEC 55014-2 requirements.

This report applies to above tested sample only. This report shall not be reproduced in parts without written approval of Shenzhen Alpha Product Testing Co., Ltd.

Tested by (name + signature).....: Lily Wang
 Project Engineer

Approved by (name + signature).....: Reak Yang
 Project Manager

Date of issue.....: February 1, 2024



Revision History

Revision	Issue Date	Revisions	Revised By
V0	February 1, 2024	Initial released Issue	Lily Wang

1. SUMMARY OF STANDARDS AND RESULTS

1.1. Description of Standards and Results

The EUT have been tested according to the applicable standards as referenced below:

EMISSION				
Description of Test Item	Standard	Limits	Results	
Conducted disturbance at mains terminals test	EN IEC 55014-1:2021	Section 4.1.1 Table 1	P	
Disturbance power test	EN IEC 55014-1:2021	Section 4.1.2 Table 2a	N/A	
Radiated disturbance	EN IEC 55014-1:2021	Section 4.1.2 Table 3	P	
Clicks	EN IEC 55014-1:2021	Section 4.2	N/A	
Harmonic current emissions	EN 61000-3-2:2019+A1:2021	Class A	N/A	
Voltage fluctuations & flicker	EN 61000-3-3:2013+A1:2019+A2:2021	Section 5	N/A	
IMMUNITY (EN IEC 55014-2:2021)				
Description of Test Item	Standard	Performance Criteria	Observation Criteria	Results
Electrostatic discharge (ESD)	IEC 61000-4-2:2008	B	A	P
Radio-frequency, Continuous radiated disturbance	IEC 61000-4-3:2020	B	A	P
Electrical fast transient	IEC 61000-4-4:2012	N/A	N/A	N/A
Surge	IEC 61000-4-5:2014+A1:2017	N/A	N/A	N/A
Radio-frequency, Continuous conducted disturbance	IEC 61000-4-6:2013	N/A	N/A	N/A
Voltage dips, Interruptions	IEC 61000-4-11:2020	N/A	N/A	N/A
Voltage dips , 60% reduction		N/A	N/A	N/A
Voltage dips, 30% reduction		N/A	N/A	N/A
<p>Note: 1. P is an abbreviation for Pass. 2. F is an abbreviation for Fail. 3. N/A is an abbreviation for Not Applicable. 4. The customer specifies radiated interference as a test item in terms of interference 5. Decision rules for the conclusion of this test report: decision by actual test data without considering measurement uncertainty.</p>				

2. GENERAL INFORMATION

2.1. Description of Device (EUT)

Description : Disposable electronic cigarette

Model Number : 77777

Diff : N/A

Test Voltage : DC 3.7V From Battery, DC 5V From Adapter

EUT Information : Input : DC 5V

Highest frequency : Less than 15MHz

Software version : N/A

Hardware version : N/A

2.2. Accessories of Device (EUT)

Power Source : N/A

2.3. Tested Supporting System Details

No.	Description	Manufacturer	Model	Serial Number
1.	Adapter	Shenzhen HUONIU Technology Co., Ltd.	HNFCQC3024UU	N/A
2.	Tester	Fei Hong Instrument Equipment Co., Ltd.	FH-Y102	N/A

2.4. Block Diagram of connection between EUT and simulators

For Tests

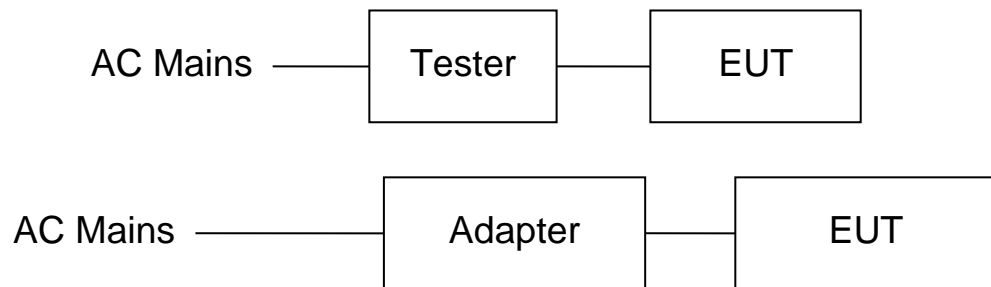

Signal Cable Description of the above Support Units					
No.	Port Name	Cable	Length	Shielded (Yes or No)	Detachable (Yes or No)
(a)	N/A	N/A	N/A	N/A	N/A

EUT: Disposable electronic cigarette

2.5. Test mode Description

For Tests

For Radiated disturbance Test		
No.	Test Mode	Test Voltage
1.	Working	DC 3.7V From Battery
2.	Charging	DC 5V From Adapter

Note: Mode 1 is worst case mode tests, so this report only reflected the worst mode in this part.

For Conducted disturbance at mains terminals Test		
No.	Test Mode	Test Voltage
1.	Charging	DC 5V From Adapter

For EMS Test		
No.	Test Mode	Test Voltage
1.	Working	DC 3.7V From Battery
2.	Charging	DC 5V From Adapter

Note: Mode 2 is worst case mode tests, so this report only reflected the worst mode in this part.

2.6. Test Facility

Shenzhen Alpha Product Testing Co., Ltd.

Building i, No.2, Lixin Road, Fuyong Street, Bao'an District, 518103, Shenzhen, Guangdong, China

2.7. Measurement Uncertainty

Test Item	Uncertainty	U _{cispr}
Uncertainty for Conduction emission test	1.63dB	3.8 dB
Uncertainty for Radiation Emission test (<1G)	3.74 dB (Distance: 3m Polarize: V)	5.2 dB
	3.76 dB (Distance: 3m Polarize: H)	
Uncertainty for Radiation Emission test (>1G)	3.77 dB (Distance: 3m Polarize: V)	5.2 dB
	3.80 dB (Distance: 3m Polarize: H)	
(95% confidence levels, k=2)		

2.8. Test Equipment

For Conducted Disturbance At Mains Terminals Test Equipment:						
Item	Equipment	Manufacturer	Model No.	Serial No.	Last Cal.	Cal. Interval
1.	Test Receiver	Rohde & Schwarz	ESCI (Firmware version: 4.42 SP1)	101165	2023.08.16	1 Year
2.	L.I.S.N.#1	Schwarz beck	NSLK8126	8126466	2023.08.16	1 Year
3.	L.I.S.N.#2	ROHDE&SCHWARZ	ENV216	101043	2023.08.16	1 Year
4.	Pulse Limiter	Schwarz beck	9516F	9618	2023.08.16	1 Year

For Frequency Range 30MHz~1GHz Radiated Emission Test Equipment:						
Item	Equipment	Manufacturer	Model No.	Serial No.	Last Cal.	Cal. Interval
1	Test Receiver	Rohde&Schwarz	ESR (Firmware version: 2.28 SP1)	1316.3003 K03-10208 2-Wa	2023.08.16	1 Year
2	Bilog Antenna	Schwarz beck	VULB 9168	VULB 9168#627	2023.08.28	2 Year

For Disturbance Power Test Equipment:						
Item	Equipment	Manufacturer	Model No.	Serial No.	Last Cal.	Cal. Interval
1.	Test Receiver	Rohde & Schwarz	ESCI (Firmware version: 4.42 SP1)	101165	2023.08.16	1 Year
2	Absorbing Clamp	Liithi	MDS-21	4054	2023.08.30	1 Year
3	N50(f-m) 6dB Fixed Attenuator	Rohde & Schwarz	A0835	J01006A0 835	2023.08.16	1 Year
4	RF Cable	Resenberger	Cable 4	N/A	2023.08.16	1 Year

For Harmonic Current Test & Voltage Fluctuations & Flicker Test Equipment:						
Item	Equipment	Manufacturer	Model No.	Serial No.	Last Cal.	Cal. Interval
1.	HARMINICS&FLICKER MEASUREMENT SYSTEM	EVERFINE	HFM300_V2 00	P630850TD1 411113	2023.04.21	1 Year

For Electrostatic Discharge Test Equipment:						
Item	Equipment	Manufacturer	Model No.	Serial No.	Last Cal.	Cal. Interval
1.	ESD Tester	TESEQ	EDS 30V	ES031000423052	2024.01.08	1 Year

For RF Field Strength Susceptibility Test Equipment:						
Item	Equipment	Manufacturer	Model No.	Serial No.	Last Cal.	Cal. Interval
1.	vector Signal Generator	Agilent	E4438C	US44271917	2023.08.16	1 Year
2.	Power meter	Agilent	E4419B	GB40202122	2023.08.16	1 Year
3.	Power Sensor	Agilent	E9300A	MY41496628	2023.08.16	1 Year
4.	RF power Amplifier	OPHIR	5225R	1045	N/A	NCR
5.	RF power Amplifier	OPHIR	5273R	1018	N/A	NCR
6.	RF power Amplifier	Micotop	MPA-3000-6000 -100	MPA1811348	N/A	NCR
7.	Antenna	SCHWARZB ECK	STLP9128E-spe cial	STLP9128E S#139	N/A	NCR
8.	Antenna	SCHWARZB ECK	STLP 9149	STLP 9149 #456	N/A	NCR

For Electrical Fast Transient/Burst Immunity, Surge, Power Frequency Magnetic Field Immunity, Voltage dips and interruptions test Equipment:						
Item	Equipment	Manufacturer	Model No.	Serial No.	Last Cal.	Cal. Interval
1.	Multifunctional Compact Immunity Test system	3ctest	CCS 600 (Firmware version: 2.28 SP1)	ES0801655	2023.08.16	1 Year
2.	Surge & EFT Coupling Decoupling Network	3ctest	SEPN 3832T	ES0951601	2023.08.16	1 Year
3.	Voltage variation and PF magnetic field regulating device	3ctest	VMT2216S	ES0441601	2023.08.16	1 Year
4.	Capacitive Coupling Clamp	3ctest	CCC 100	EC0441660	2023.08.16	1 Year

For Injected currents susceptibility test Equipment:						
Item	Equipment	Manufacturer	Model No.	Serial No.	Last Cal.	Cal. Interval
1.	Conducted Immunity test System	SKET	CITS_150K2 30M	SK201910100 1_CITS	2023.08.16	1 Year
2.	Fixed Coaxial Attenuator (6dB Attenuation)	CD	ATT-0675	120540086	2023.08.16	1 Year
3.	coupling-decoupling network (CDN)	CD	CDN M2/M3	2302	2023.08.16	1 Year
4.	Electromagnetic Injection Clamp (EMC-Clamp)	CD	EM-Clamp	0513A031201	2023.08.16	1 Year

Software Information			
Test Item	Software Name	Manufacturer	Version
RE	EZ-EMC	Farad	Alpha-3A1
CE	EZ-EMC	Farad	Alpha-3A1

2.9. Classification Of Apparatus Description

Category I: apparatus containing no electronic control circuitry.

Electric circuits consisting of passive components (such as radio interference suppression capacitors or inductors, mains transformers and mains frequency rectifiers) are not considered to be electronic control circuitry.

Category II : mains operated equipment containing electronic control circuitry with noclock frequency higher than 15 MHz.

Category III : battery operated equipment not included in Category I.

This category also includes equipment provided with rechargeable batteries, which can be charged, directly or indirectly, from the mains. Accordingly, this equipment shall also be subjected to the test requirements for mains operated equipment but only when testing the charging function.

If the equipment can operate its intended functions when connected, directly or indirectly to the mains, then it is not battery operated. Accordingly, it shall be classified as Category II, Category IV or Category V, as applicable, and subjected to the corresponding test requirements when in mains operation.

EXAMPLES : Appliances, tools and toys powered by batteries and that include a microprocessor to provide a selection of functions.

NOTE : The assignment to Category III is independent of the clock frequency.

Category IV : mains operated equipment containing electronic control circuitry with a highest clock frequency greater than 15 MHz but lower than or equal to 200 MHz.

Category V : mains operated equipment containing electronic control circuitry with a highest clock frequency greater than 200 MHz.

3. CONDUCTED DISTURBANCE AT MAINS TERMINALS TEST

3.1. Block Diagram of Test Setup

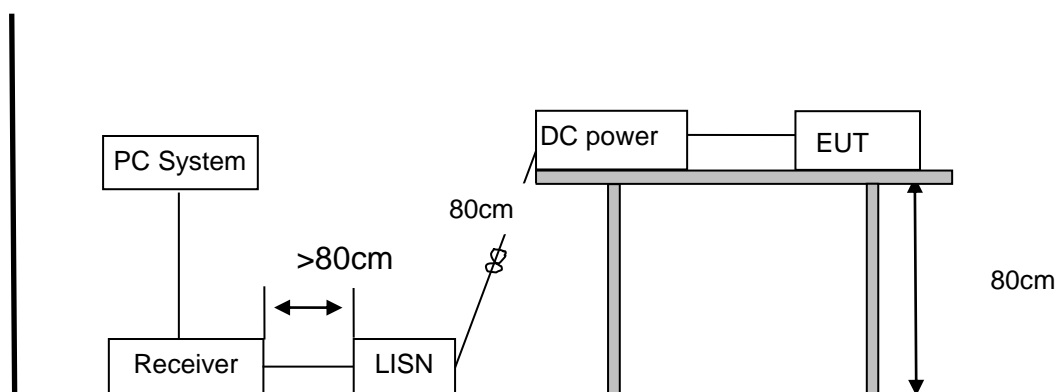

3.2. Power Line Conducted Emission Test Limits

Frequency	Maximum RF Line Voltage	
	Quasi-Peak Level dB(μ V)	Average Level dB(μ V)
150kHz ~ 500kHz	66 ~ 56*	59 ~ 46*
500kHz ~ 5MHz	56	46
5MHz ~ 30MHz	60	50

- Notes:
1. Emission level=Read level + LISN factor-Preamp factor + Cable loss
 2. * Decreasing linearly with logarithm of frequency.
 3. The lower limit shall apply at the transition frequencies.

3.3. Configuration of EUT on Test

The following equipment are installed on conducted disturbance at mains terminals to meet the EN IEC 55014-1 requirement and operating regulations in a manner which tends to maximize its emission characteristics in a normal application.

3.4. Operating Condition of EUT

- (1) Setup the EUT as shown as Section 3.2.
- (2) Turn on the power of all equipment.
- (3) Let the EUT work in test mode and 15 minutes before taking the test.

3.5. Test Procedure

- (1) The EUT was placed on a non-metallic table, 80cm above the ground plane. The EUT Power connected to the power mains through a line impedance stabilization network (L.I.S.N. 1#). This provided a 50-ohm coupling impedance for the EUT (Please refer to the block diagram of the test setup and photographs). The other peripheral devices power cord connected to the power mains through a line impedance stabilization network (L.I.S.N.#2). Both sides of power line were checked for maximum conducted interference. In order to find the maximum emission, the relative positions of equipments and all of the interface cables were changed according to EN IEC 55014-1 on Conducted Disturbance at Mains Terminals test.
- (2) The frequency range from 150kHz to 30MHz is checked, the bandwidth of test receiver (R&S TEST RECEIVER ESCI) is set at 9kHz.
- (3) The test results are reported on Section 3.6.

3.6. Conducted Disturbance at Mains Terminals Test Results

EUT	: Disposable electronic cigarette	Test Date	: 2024.1.30
M/N	: 77777	Temperature	: 21.8°C
Test Engineer	: Lily Wang	Humidity	: 44%
Test Voltage	: DC 5V From Adapter	Pressure	: 101.3KPa
Test Mode	: Charging		
Test Results	: PASS		
Note	<p>1. The test results are listed in next pages.</p> <p>2. If the limits for the measurement with the average detector are met when using a receiver with a peak detector, the test unit shall be deemed to meet both limits and the measurement with the average detector and quasi-peak detector need not be carried out.</p> <p>3. If the limits for the measurement with the average detector are met when using a receiver with a quasi-peak detector, the test unit shall be deemed to meet both limits and the measurement with the average detector need not be carried out.</p>		

Polarization: Line

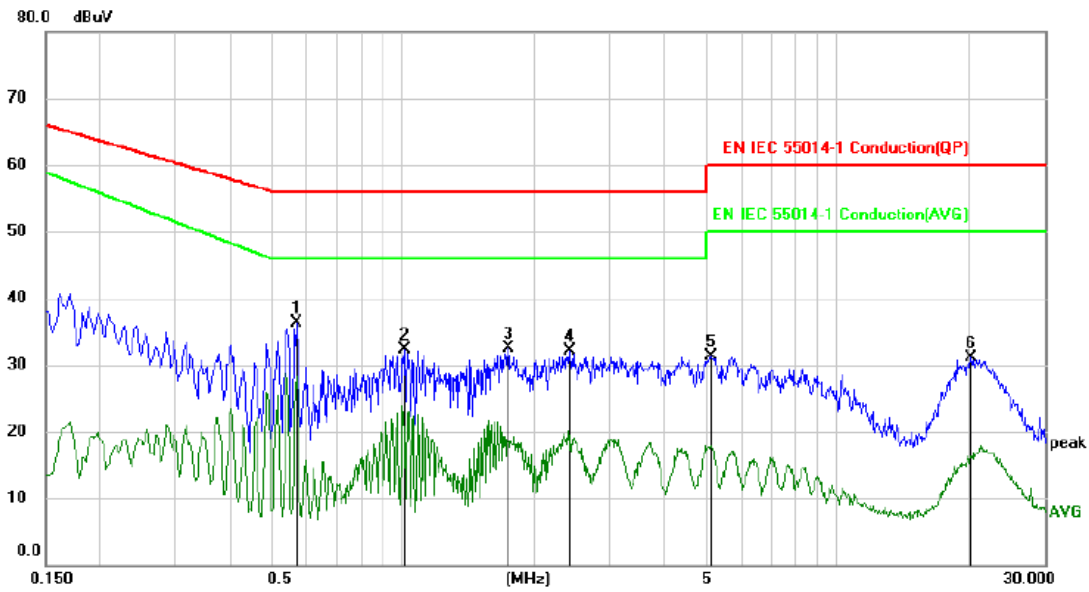

No. Mk.	Freq. MHz	Reading Level dBuV	Correct Factor dB	Measure- ment dBuV	Limit dBuV	Margin dB	Detector	Comment
1 *	0.5700	26.43	9.93	36.36	56.00	-19.64	peak	
2	1.0050	22.29	9.92	32.21	56.00	-23.79	peak	
3	1.7460	22.56	9.89	32.45	56.00	-23.55	peak	
4	2.4210	22.15	9.90	32.05	56.00	-23.95	peak	
5	5.1180	21.34	10.04	31.38	60.00	-28.62	peak	
6	20.2890	20.63	10.46	31.09	60.00	-28.91	peak	

*:Maximum data x:Over limit !:over margin (Reference Only)

Note: Measurement=Reading Level+Correc Factor. Factor=(LISN or ISN or PLC or Current Probe)Factor+Cable

Polarization: Neutral

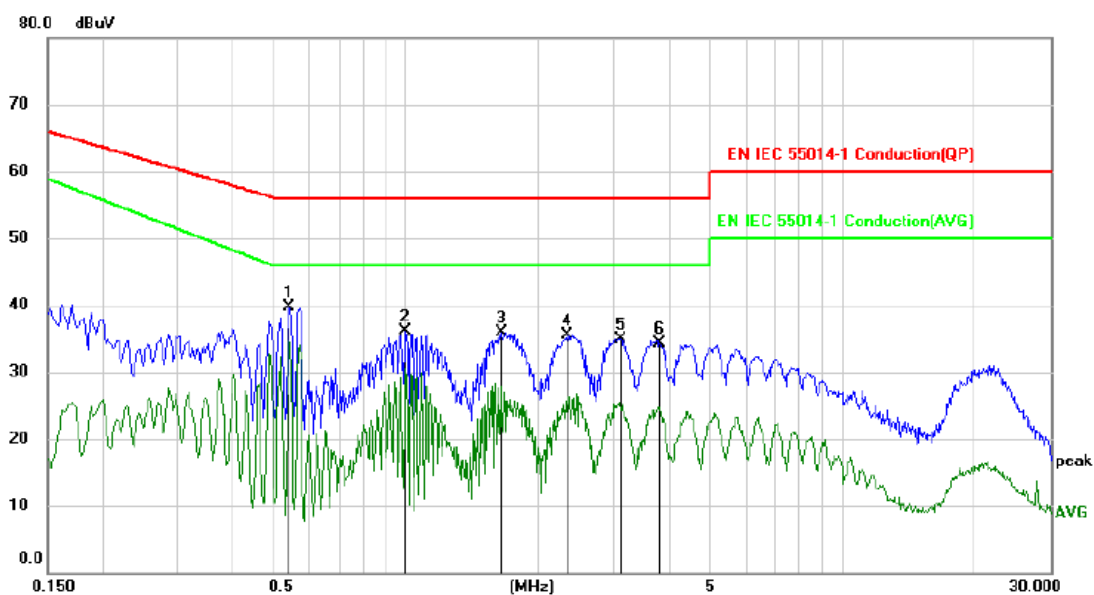

No.	Mk.	Freq. MHz	Reading Level dBuV	Correct Factor dB	Measure- ment dBuV	Limit dBuV	Margin dB	Detector	Comment
1	*	0.5400	29.86	9.94	39.80	56.00	-16.20	peak	
2		0.9990	26.10	9.92	36.02	56.00	-19.98	peak	
3		1.6530	26.03	9.89	35.92	56.00	-20.08	peak	
4		2.3460	25.58	9.90	35.48	56.00	-20.52	peak	
5		3.1050	25.01	9.96	34.97	56.00	-21.03	peak	
6		3.8040	24.38	9.96	34.34	56.00	-21.66	peak	

*:Maximum data x:Over limit !:over margin

(Reference Only)

Note: Measurement=Reading Level+Correc Factor. Factor=(LISN or ISN or PLC or Current Probe)Factor+Cable

4. DISTURBANCE POWER TEST

4.1. Block Diagram of Test Setup

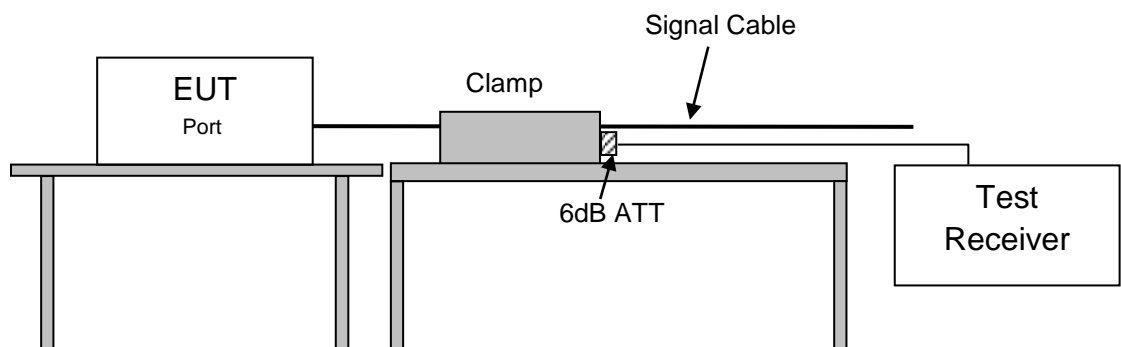

4.2. Disturbance Power Test Limits

For Household and similar appliances and Rated motor power not exceeding 700 W Tools:

Frequency	Interference Power Limits	
	Quasi-Peak Level dB(pW)	Average Level dB(pW)
30MHz ~ 300MHz	45 Increasing Linearly with Frequency to 55	35 Increasing Linearly with Frequency to 45

For Rated motor power above 700 W and not exceeding 1 000 W Tools:

Frequency	Interference Power Limits	
	Quasi-Peak Level dB(pW)	Average Level dB(pW)
30MHz ~ 300MHz	49 Increasing Linearly with Frequency to 59	39 Increasing Linearly with Frequency to 49

Notes: Emission level=Read level + Clamp factor-Preamp factor + Cable loss

4.3. Configuration of EUT on Test

The EN55014-1 regulations test method must be used to find the maximum emission during radiated power test. Any lead connecting the EUT to an auxiliary apparatus is disconnected if this does not affect the operation of the EUT, or is isolated by means of absorbing clamp close to the EUT, a similar measure was made on each lead which is or may be connected to an auxiliary apparatus, whether or not it is necessary for the operation of the EUT.

4.4. Operating Condition of EUT

- (1) Setup the EUT as shown as Section 4.2.
- (2) Turn on the power of all equipment.
- (3) Let the EUT work in test mode and 15 minutes before taking the test.

4.5. Test Procedure

- (1) The EUT is placed on the table which is high 0.8m by insulating support and away from other metallic surface at least 0.8m. It is connected to the power mains through an extension cord of 6m minimums. The absorber clamp was clamps the cord and moves from the far end to EUT to measure the disturbing energy emitted from the cord.
- (2) The frequency range from 30MHz to 300MHz is checked, the bandwidth of test receiver (R&S TEST RECEIVER ESCI) is set at 120kHz.
- (3) The test results are reported on Section 4.6.

4.6. Disturbance Power Test Results

EUT	: Disposable electronic cigarette	Test Date	: N/A
M/N	: 77777	Temperature	: N/A
Test Engineer	: N/A	Humidity	: N/A
Test Voltage	: N/A	Pressure	: N/A
Test Mode	: N/A		
Test Results	: N/A		
Note: 1.The customer specifies radiated interference as a test item in terms of interference			

5. RADIATED DISTURBANCE TEST

5.1. Block Diagram of Test Setup

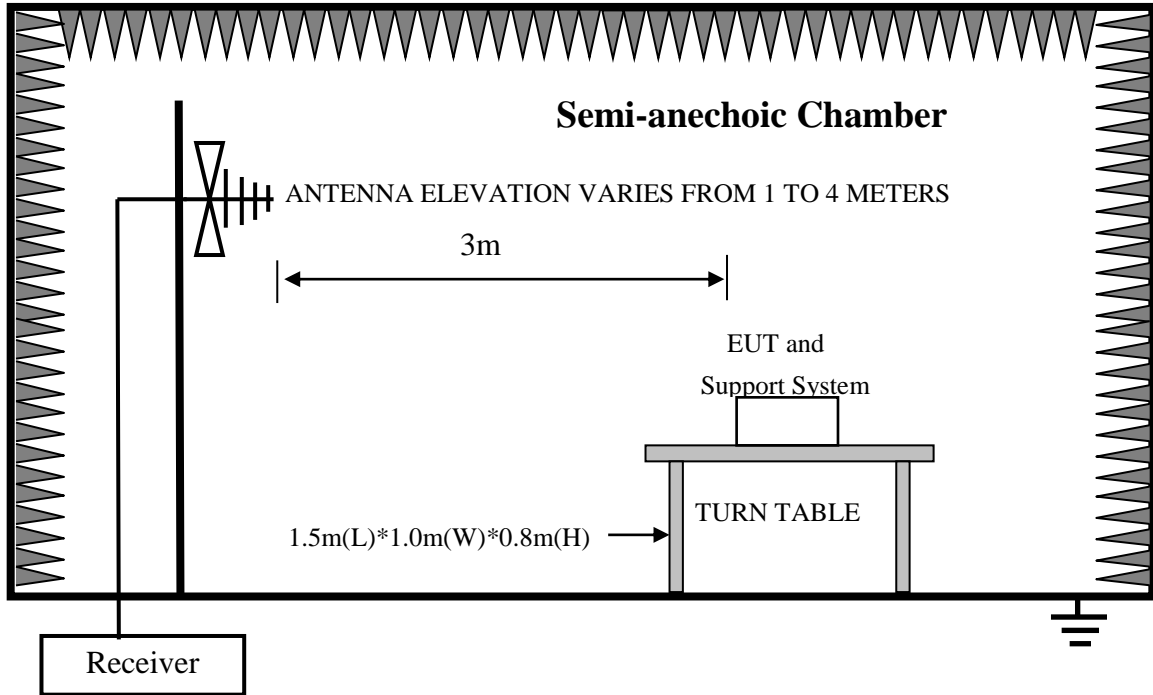

For 3m distance description:

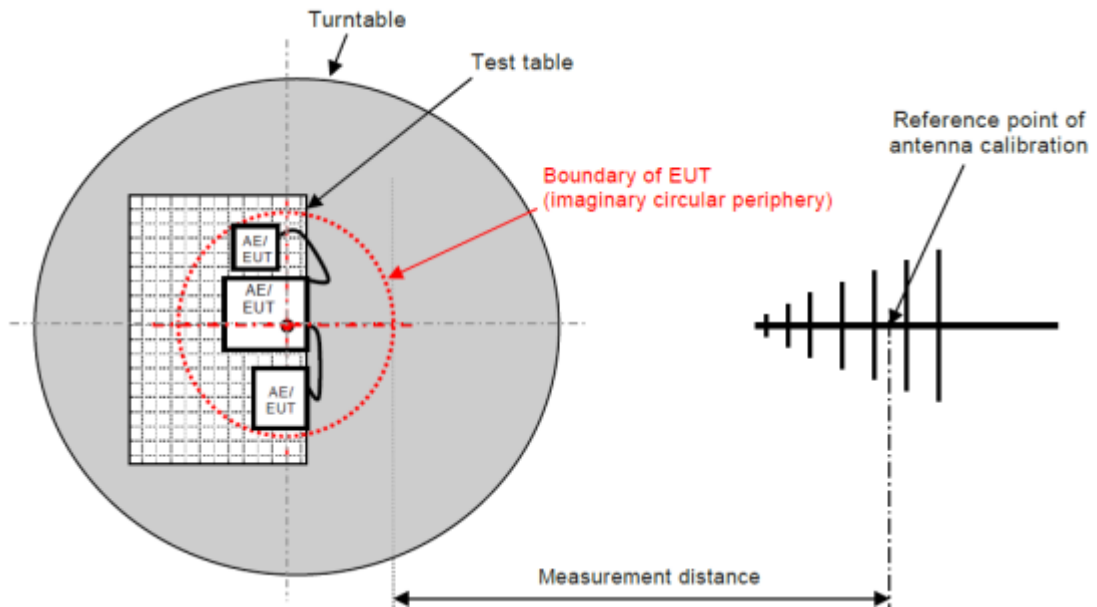

5.2. Radiated Emission Limit

Frequency MHz	Distance (Meters)	Field Strengths Limits dB(μ V)/m
30 ~ 230	3	40
230 ~ 1000	3	47

- Notes:
1. Emission level = Read level + Antenna Factor - Preamp Factor + Cable Loss
 2. The smaller limit shall apply at the cross point between two frequency bands.
 3. Distance is the distance in meters between the measuring instrument, antenna and the closest point of any part of the device or system.

5.3. Configuration of EUT on Test

The following equipment are installed on Radiated Emission Test to meet the EN IEC 55014-1 requirements and operating regulations in a manner that tends to maximize its emission characteristics in normal application.

5.4. Operating Condition of EUT

- (1) Setup the EUT as shown as Section 5.1.
- (2) Turn on the power of all equipment.
- (3) Let the EUT work in test mode and 15 minutes before taking the test.

5.5. Test Procedure

- (1) The EUT was placed on a non-metallic table, 80 cm above the ground plane inside a semi-anechoic chamber. An antenna was located 3m from the EUT on an adjustable mast. A pre-scan was first performed in order to find prominent radiated emissions. For final emissions measurements at each frequency of interest, the EUT were rotated and the antenna height was varied between 1m and 4m in order to maximize the emission. Measurements in both horizontal and vertical polarities were made and the data was recorded. In order to find the maximum emission, the relative positions of equipments and all the interface cables were changed according to EN IEC 55014 on Radiated Disturbance test.
- (2) The frequency range from 30MHz to 1000MHz is checked, the bandwidth of test receiver (R&S TEST RECEIVER ESR) is set at 120kHz.
- (3) The frequency range from 30MHz to 1000MHz was pre-scanned with a peak detector and all final readings of measurement from Test Receiver are Quasi-Peak values, all measurement distance is 3m in 3m semi anechoic chamber.
- (4) The test results are reported on Section 5.6.

5.6.Radiated Disturbance Test Results

EUT	: Disposable electronic cigarette	Test Date	: 2024.1.30
M/N	: 77777	Temperature	: 22.1°C
Test Engineer	: Lily Wang	Humidity	: 38%
Test Voltage	: DC 3.7V From Battery	Pressure	: 101.3KPa
Test Mode	: Working		
Test Results	: PASS		
Note:	1. The test results are listed in next pages.		

Antenna Polarity: V

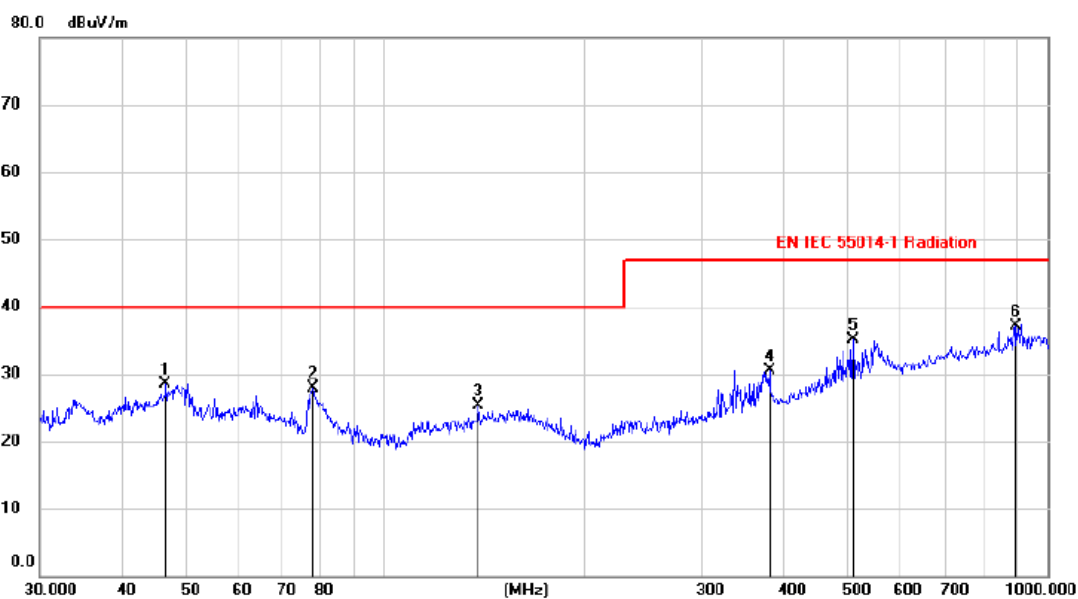

No.	Mk.	Freq.	Reading Level	Correct Factor	Measurement	Limit	Margin	Antenna Height	Table Degree
		MHz	dBuV	dB	dBuV/m	dBuV/m	dB	cm	degree
1		46.6609	14.32	14.09	28.41	40.00	-11.59	peak	
2		77.7290	17.75	10.20	27.95	40.00	-12.05	peak	
3		138.0641	11.05	14.17	25.22	40.00	-14.78	peak	
4		380.4919	14.64	15.93	30.57	47.00	-16.43	peak	
5		508.5553	16.83	18.36	35.19	47.00	-11.81	peak	
6	*	893.9611	13.23	23.96	37.19	47.00	-9.81	peak	

Note: 1. *:Maximum data; x:Over limit; !:over margin.

2.Measurement=Reading Level+Correct Factor; Correct Factor=Antenna Factor+Cable Loss.

Antenna Polarity: H

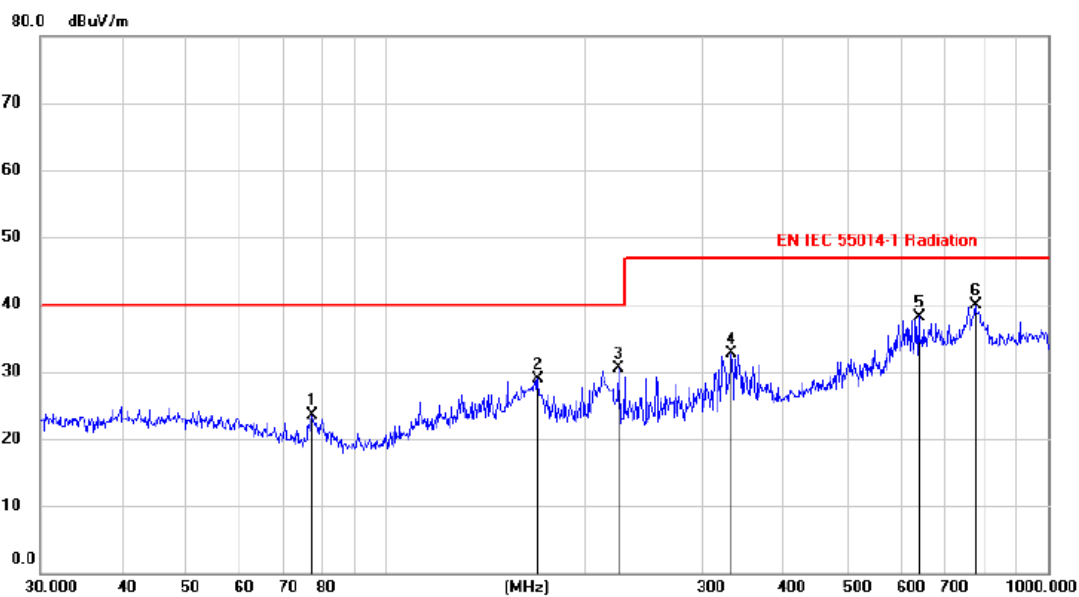

No.	Mk.	Freq.	Reading Level	Correct Factor	Measurement	Limit	Margin	Antenna Height	Table Degree
		MHz	dBuV	dB	dBuV/m	dBuV/m	dB	cm	degree
1		77.5383	13.37	10.20	23.57	40.00	-16.43	peak	
2		170.1152	14.88	14.06	28.94	40.00	-11.06	peak	
3		224.9922	18.41	12.02	30.43	40.00	-9.57	peak	
4		333.0242	17.83	14.90	32.73	47.00	-14.27	peak	
5		639.0405	17.24	20.96	38.20	47.00	-8.80	peak	
6	*	778.2411	17.14	22.77	39.91	47.00	-7.09	peak	

Note: 1. *:Maximum data; x:Over limit; !:over margin.

2.Measurement=Reading Level+Correct Factor; Correct Factor=Antenna Factor+Cable Loss.

6. CLICKS

The EUT which fulfill the following condition:

- the click rate is no more than 5;
- none of the caused clicks has duration longer than 20 ms,
- 90% of the caused clicks have a duration less than 10 ms (measured duration time is 0.4ms), was deemed to comply with the limits.

The disturbance from individual switching operations, caused directly or indirectly, manually or by similar activities on a switch or a control which is included in an appliance or otherwise to be used for:

- a) the purpose of mains connection or disconnection only;
- b) the purpose of programmer selection only;
- c) the control of energy or speed by switching between a limited number of fixed positions;
- d) the changing of the manual setting of a continuously adjustable control such as a variable speed device for water extraction or electronic thermostats, is to be disregarded for the purpose of testing the appliance for compliance with the limits of radio disturbance set out in this standard.

Also the disturbance caused by the operation of any switching device or control which is included in an appliance for the purpose of mains disconnection for safety only, is to be disregarded for the purpose of testing the appliance for compliance with the limits of radio disturbance as described in this standard.

7. HARMONIC CURRENT TEST

7.1. Block Diagram of Test Setup

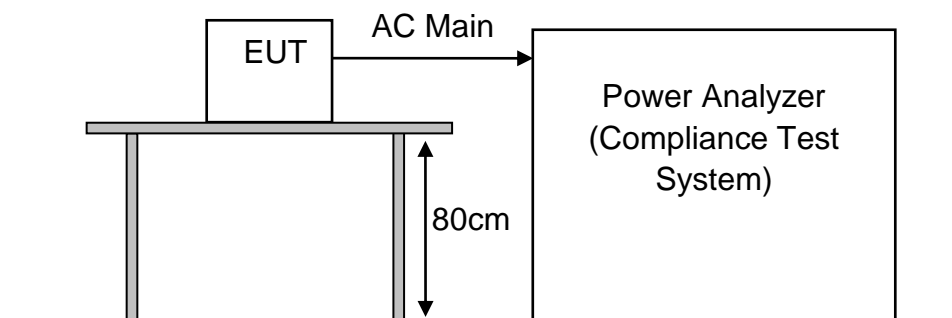

7.2. Harmonic Current Test Limits

For Class A equipment:

Harmonic order n	Maximum permissible harmonic current A
Odd harmonics	
3	2,30
5	1,14
7	0,77
9	0,40
11	0,33
13	0,21
$15 \leq n \leq 39$	$0,15 \frac{15}{n}$
Even harmonics	
2	1,08
4	0,43
6	0,30
$8 \leq n \leq 40$	$0,23 \frac{8}{n}$

for Class B equipment:

The harmonics of the input current shall not exceed the values given in Class A equipment limit multiplied by a factor of 1,5.

7.3. Configuration of EUT on Test

The following equipment are installed on Harmonic Current Test to meet the EN61000-3-2 requirements and operating regulations in a manner that tends to maximize its emission characteristics in normal application.

7.4. Operating Condition of EUT

- (1) Setup the EUT as shown as Section 7.2.
- (2) Turn on the power of all equipment.
- (3) Let the EUT work in test mode and 15 minutes before taking the test.

7.5. Test Procedure

- (1) The EUT was placed on the top of a wooden table 0.8 meters above the ground and operated to produce the maximum harmonic components under normal operating conditions for each successive harmonic component in turn. The correspondent test program of test instrument to measure the current harmonics emanated from EUT is chosen. The measure time shall be not less than the necessary for the EUT to be exercised.
- (2) The test results are reported on Section 7.6.

7.6. Harmonic Current Test Results

EUT	: Disposable electronic cigarette	Test Date	: N/A
M/N	: 77777	Temperature	: N/A
Test Engineer	: N/A	Humidity	: N/A
Test Voltage	: N/A	Pressure	: N/A
Test Mode	: N/A		
Test Results	: N/A		
Note: Not applicable for equipment operated with Battery DC supply.			

8. VOLTAGE FLUCTUATIONS & FLICKER TEST

8.1. Block Diagram of Test Setup

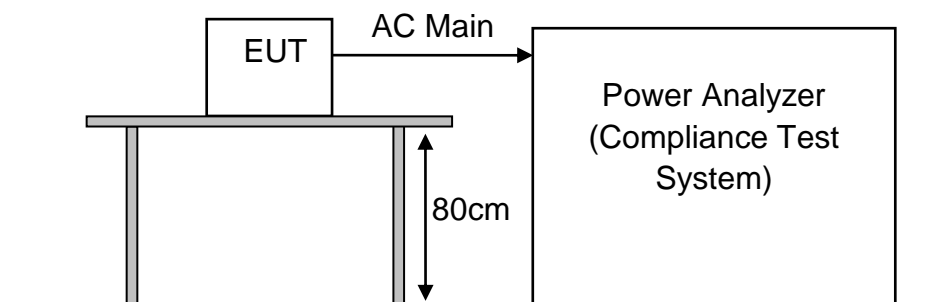

8.2. Voltage Fluctuation and Flicker Test Limits

Test Item	Limit	Note
P_{st}	1.0	P_{st} means Short-term flicker indicator
P_{lt}	0.65	P_{lt} means long-term flicker indicator
T_{dt}	0.2	T_{dt} means maximum time that dt exceeds 3%
$d_{max}(\%)$	4%	d_{max} means maximum relative voltage change.
$d_c(\%)$	3.3%	d_c means relative steady-state voltage change.

8.3. Configuration of EUT on Test

The following equipment are installed on Harmonic Current Test to meet the EN61000-3-3 requirements and operating regulations in a manner that tends to maximize its emission characteristics in normal application.

8.4. Operating Condition of EUT

- (1) Setup the EUT as shown as Section 8.2.
- (2) Turn on the power of all equipment.
- (3) Let the EUT work in test mode and 15 minutes before taking the test.

8.5. Test Procedure

- (1) The EUT was placed on the top of a wooden table 0.8 meters above the ground and operated to produce the most unfavorable sequence of voltage changes under normal conditions During the flick measurement; the measure time shall include that part of whole operation changes. The observation period for short-term flicker indicator is 10 minutes and the observation period for long-term flicker indicator is 2 hours.
- (2) The test results are reported on Section 8.6.

8.6.Voltage Fluctuation and Flicker Test Results

EUT	: Disposable electronic cigarette	Test Date	: N/A
M/N	: 77777	Temperature	: N/A
Test Engineer	: N/A	Humidity	: N/A
Test Voltage	: N/A	Pressure	: N/A
Test Mode	: N/A		
Test Results	: N/A		
Note: Not applicable for equipment operated with Battery DC supply.			

9. Immunity Performance Criteria

Performance Level

The test results shall be classified in terms of the loss of function or degradation of performance of the equipment under test, relative to a performance level by its manufacturer or the requestor of the test, or the agreed between the manufacturer and the purchaser of the product.

Definition related to the performance level:

1. Based on the used product standard
2. Based on the declaration of the manufacturer, requestor or purchaser

Criterion A:

The apparatus shall continue to operate as intended during the test. No degradation of performance or loss of function is allowed below a performance level (or permissible loss of performance) specified by the manufacturer, when the apparatus is used as intended. If the minimum performance level or the permissible performance loss is not specified by the manufacturer, then either of these may be derived from the product description and documentation, and from what the user may reasonably expect from the apparatus if used as intended.

Criterion B:

The apparatus shall continue to operate as intended after the test. No degradation of performance or loss of function is allowed below a performance level (or permissible loss of performance) specified by the manufacturer, when the apparatus is used as intended. During the test, degradation of performance is allowed, however no change of actual operating state or stored data is allowed to persist after the test. If the minimum performance level or the permissible performance loss is not specified by the manufacturer, then either of these may be derived from the product description and documentation, and from what the user may reasonably expect from the apparatus if used as intended.

Criterion C:

Temporary loss of function is allowed, provided the function is self-recoverable or can be restored by the operation of the controls, or by any operation specified in the instructions for use.

10. ELECTROSTATIC DISCHARGE TEST

10.1. Block Diagram of Test Setup

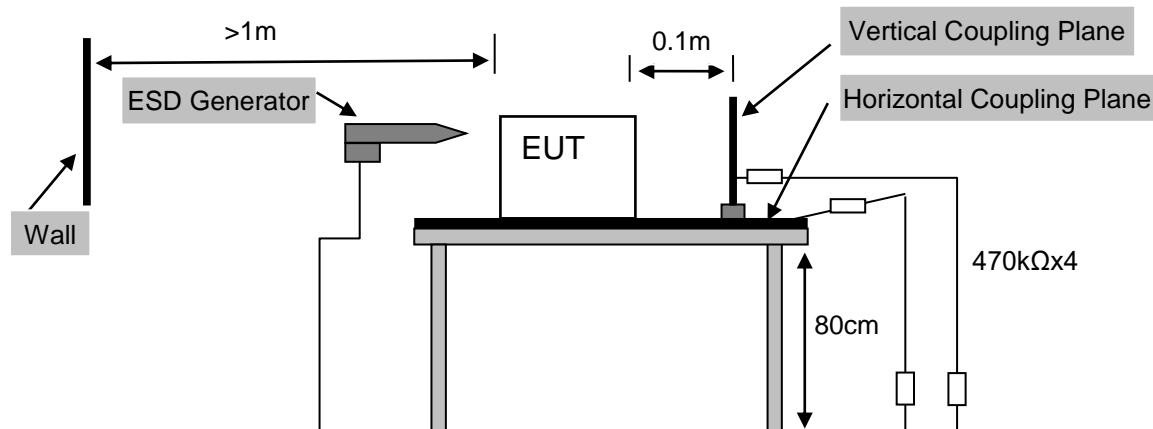

10.2. Electrostatic Discharge Test Limits

Test Type	Test Level	Performance Criterion
Air Discharge	8KV	B
Contact Discharge	4KV	B

Notes:

1. A performance criterion C could be applied to toys not using score or data entered by the user. Examples are musical soft toys, sounding toys, etc.
2. Test set-up reference IEC 61000-4-2:2008

10.3. Configuration of EUT on Test

The following equipment are installed on Electrostatic Discharge Test to meet the IEC 61000-4-2 requirements and operating regulations in a manner that tends to maximize its emission characteristics in normal application.

10.4. Operating Condition of EUT

- (1) Setup the EUT as shown as Section 10.1.
- (2) Turn on the power of all equipment.
- (3) Let the EUT work in test mode and 15 minutes before taking the test.

10.5. Test Procedure

(1) Air Discharge:

The test was applied on non-conductive surfaces of EUT. The round discharge tip of the discharge electrode was approached as fast as possible to touch the EUT. After each discharge, the discharge electrode was removed from the EUT. The generator was re-triggered for a new single discharge and repeated 20 times (10 with positive and 10 negative with positive) for each pre-selected test point. This procedure was repeated until all the air discharge completed.

(2) Contact Discharge:

All the procedure was same as Section 9.6.1. Except that the generator was re-triggered for a new single discharge for each pre-selected test point. The tip of the discharge electrode was touching the EUT before the discharge switch was operated.

(3) Indirect discharge for horizontal coupling plane:

At least 20 single discharges (10 with positive and 10 negative with positive) were applied to the horizontal coupling plane, at points on each side of the EUT. The discharge electrode positions vertically at a distance of 0.1m from the EUT and with the discharge electrode touching the coupling plane.

(4) Indirect discharge for vertical coupling plane:

At least 20 single discharge (10 with positive and 10 negative with positive) were applied to the center of one vertical edge of the coupling plane. The coupling plane, of dimensions 0.5m X 0.5m, was placed parallel to, and positioned at a distance of 0.1m from the EUT. Discharges were applied to the coupling plane, with this plane in sufficient different positions that the four faces of the EUT are completely illuminated.

10.6. Electrostatic Discharge Test Results

EUT	: Disposable electronic cigarette	Test Date	: 2024.1.30	
M/N	: 77777	Temperature	: 22.5°C	
Test Engineer	: Lily Wang	Humidity	: 50%	
Test Voltage	: DC 5V From Adapter	Pressure	: 101.3KPa	
Test Mode	: Charging			
Test Results	: PASS			
Discharge Voltage (kV)	Type Of Discharge	Dischargeable Points	Performance	
			Required	Observation
±4	Contact	N/A	B	N/A
±8	Air	1, 2	B	A
±4	HCP-Bottom	Edge of the HCP	B	A
±4	VCP-Front	Center of the VCP	B	A
±4	VCP-Left	Center of the VCP	B	A
±4	VCP-Back	Center of the VCP	B	A
±4	VCP-Right	Center of the VCP	B	A
Discharge Points Description				
1	Gap	4	N/A	
2	Port	5	N/A	
3	N/A	6	N/A	
Note:	<p>1. For the time interval between successive single discharges an initial value of one second.</p> <p>2. For Air Discharge each Point Positive 10 times and negative 10 times discharge.</p> <p>3. Class A is no function loss.</p> <p>4. EUT does not contain metal contact points, not need to contact discharge measurement.</p>			

11. RF FIELD STRENGTH SUSCEPTIBILITY TEST

11.1. Block Diagram of Test Setup

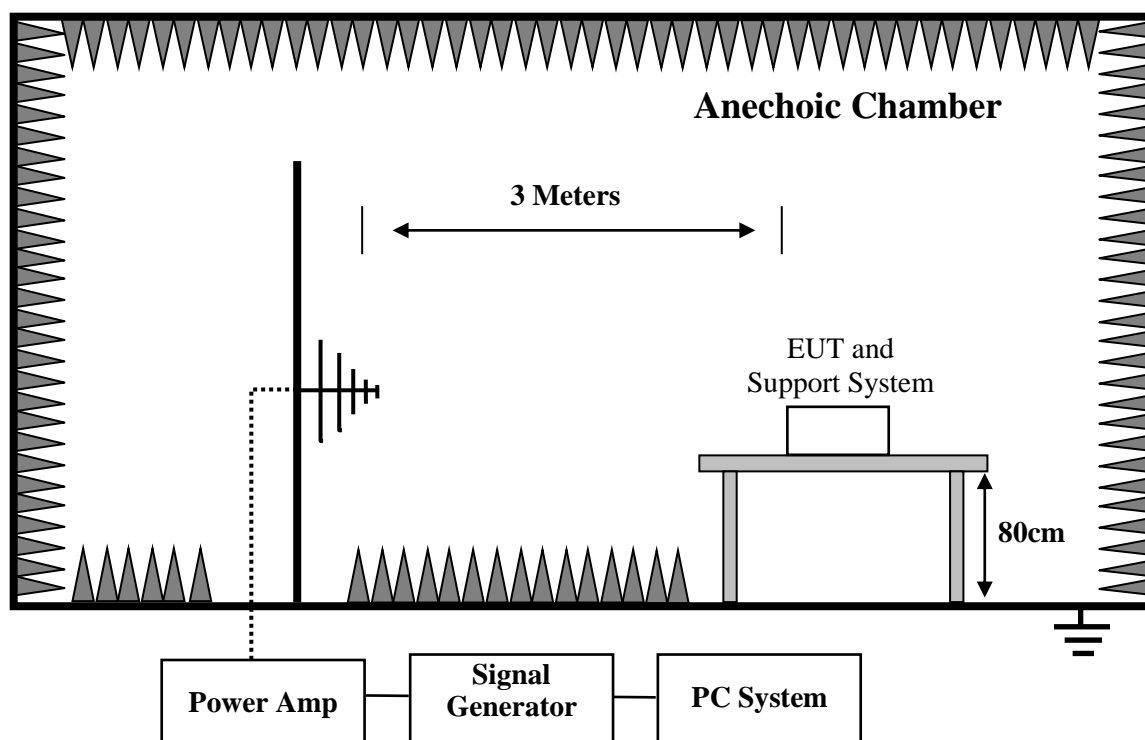

11.2. RF Field Strength susceptibility Test Limits

Test Specifications	Test Level	Performance Criterion
80MHz-1000MHz	3V/m (r.m.s.)	A

Notes: 1. Test set-up reference IEC 61000-4-3:2006 + A1:2007 + A2:2010

11.3. Configuration of EUT on Test

The following equipment are installed on Electrostatic Discharge Test to meet the IEC 61000-4-3 requirements and operating regulations in a manner that tends to maximize its emission characteristics in normal application.

11.4. Operating Condition of EUT

- (1) Setup the EUT as shown as Section 11.1.
- (2) Turn on the power of all equipment.
- (3) Let the EUT work in test mode and 15 minutes before taking the test.

11.5. Test Procedure

- (1) Testing was performed in a Fully anechoic chamber as recommended by IEC 61000-4-3. The EUT was placed on an 80 cm high non-conductive table located in the area of field uniformity.
- (2) The radiating antenna was placed 3m in front of the EUT and Support system, and dwell time of the radiated interference was controlled by an automated, computer-controlled system. The signal source was stepped through the applicable frequency range at a rate no faster than 1% of the fundamental. The signal was amplitude modulated 80% over the frequency range
- (3) 80 MHz to 1GHz at a level of 3 V/m. The dwell time was set at 3 s. Field presence was monitored during testing via a field probe placed in close proximity to the EUT.
- (4) Throughout testing, the EUT was closely monitored for signs of susceptibility. The test was performed with the antennae oriented in both a horizontal and vertical polarization.
- (5) All the scanning conditions are as follows:

Condition of Test	Require of Test
Test Fielded Strength	3 V/m
Radiated Signal	80% amplitude modulated with a 1kHz sine wave
Scanning Frequency	80 - 1000 MHz
Sweeping time of radiated	0.0015 decade/s
Dwell Time	1 Sec.

11.6.RF Field Strength Susceptibility Test Results

EUT	: Disposable electronic cigarette	Test Date	: 2024.1.30		
M/N	: 77777	Temperature	: 22.2°C		
Test Engineer	: Lily Wang	Humidity	: 49%		
Test Voltage	: DC 5V From Adapter	Pressure	: 101.3KPa		
Test Mode	: Charging				
Test Results	: PASS				
Field Strength	: 3V/m				
Modulation: <input checked="" type="checkbox"/> AM <input type="checkbox"/> Pulse <input type="checkbox"/> none 1 kHz 80%					
Frequency Range :80 MHz -1000MHz					
Steps	1%				
	Horizontal		Vertical	Result	
	Required	Observation	Required	Observation	(Pass / Fail)
Front	A	A	A	A	Pass
Right	A	A	A	A	Pass
Rear	A	A	A	A	Pass
Left	A	A	A	A	Pass
Note: Class A is no function loss					

12. ELECTRICAL FAST TRANSIENT/BURST IMMUNITY TEST

12.1. Block Diagram of Test Setup

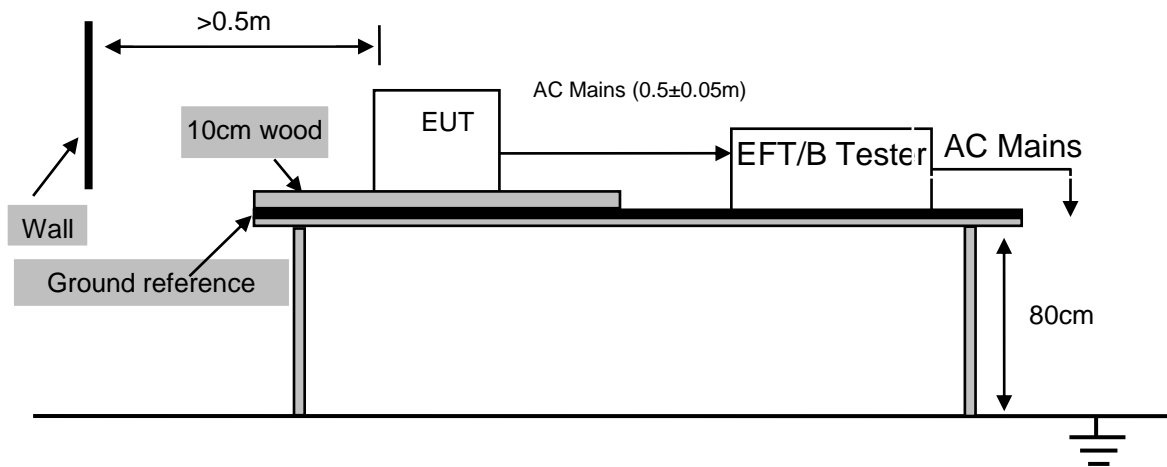

12.2. Test Standard

EN IEC 55014 -2:2021
(Severity Level 2 at 1kV)

12.3. Electrical Fast Transient/Burst Test Limits

Level	On Power Supply Lines	On I/O (Input/Output) Signal data and control lines
1	0.5 kV	0.25 kV
2	1 kV	0.5 kV
3	2 kV	1 kV
4	4 kV	2 kV
X	Special	Special

Notes:

1. Test set-up reference IEC 61000-4-4:2012
2. Performance criterion : **B**

12.4. Configuration of EUT on Test

The following equipment are installed on Electrostatic Discharge Test to meet the IEC 61000-4-4 requirements and operating regulations in a manner that tends to maximize its emission characteristics in normal application.

12.5. Operating Condition of EUT

- (1) Setup the EUT as shown as Section 12.1.
- (2) Turn on the power of all equipment.
- (3) Let the EUT work in test mode and 15 minutes before taking the test.

12.6. Test Procedure

The EUT and its simulators were placed on the ground reference plane and were insulated from it by a wood support 0.1m + 0.01m thick. The ground reference plane was 1m*1m metallic sheet with 0.65mm minimum thickness. This reference ground plane was project beyond the EUT by at least

- (1) 0.1m on all sides and the minimum distance between EUT and all other conductive structure, except the ground plane was more than 0.5m. All cables to the EUT was placed on the wood support, cables not subject to EFT/B was routed as far as possible from the cable under test to minimize the coupling between the cables.

12.6.1. For input and AC power ports:

The EUT was connected to the power mains by using a coupling device that couples the EFT interference signal to AC power lines. Both positive transients and negative transients of test voltage were applied during compliance test and the duration of the test can't less than 2 min.

12.6.2. For signal lines and control lines ports:

No I/O ports. It's unnecessary to test.

12.6.3. For DC input and DC output power ports:

It's unnecessary to test.

12.7.Electrical Fast Transient/Burst immunity Test Results

EUT	: Disposable electronic cigarette	Test Date	: N/A
M/N	: 77777	Temperature	: N/A
Test Engineer	: N/A	Humidity	: N/A
Test Voltage	: N/A	Pressure	: N/A
Test Mode	: N/A		
Test Results	: N/A		
Note: Not applicable for equipment operated with PC, Battery, or Power Supply.			

13. SURGE TEST

13.1. Block Diagram of Test Setup

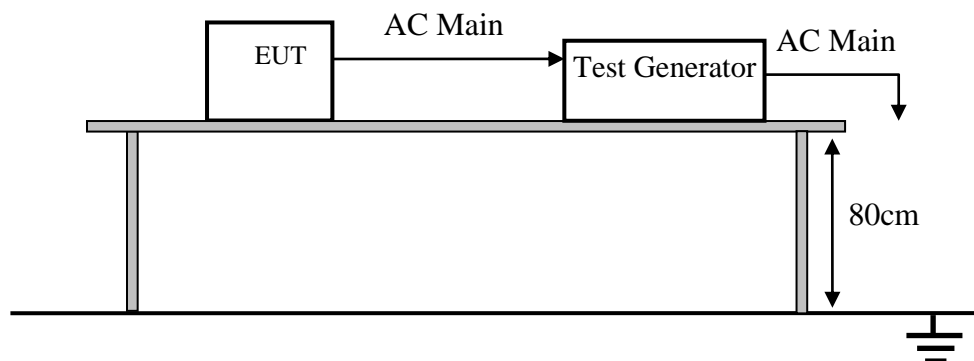

13.2. Surge Test Limits

Environmental phenomenon	Test specifications	Test set-up
Surge	1,2/50 (8/20) μ s Tr/Td 2 kV line-to-earth with 12 Ω Impedance 1 kV line-to-line with 2 Ω Impedance	IEC 61000-4-5

Severity level

Severity Level [Ⓢ]	Open-Circuit Test Voltage [Ⓢ] kV [Ⓢ]
1 [Ⓢ]	0.5 [Ⓢ]
2 [Ⓢ]	1.0 [Ⓢ]
3 [Ⓢ]	2.0 [Ⓢ]
4 [Ⓢ]	4.0 [Ⓢ]
* [Ⓢ]	Special [Ⓢ]

Performance criterion : B

13.3. Configuration of EUT on Test

The following equipment are installed on Electrostatic Discharge Test to meet the IEC 61000-4-5 requirements and operating regulations in a manner that tends to maximize its emission characteristics in normal application.

13.4. Operating Condition of EUT

- (1) Setup the EUT as shown as Section 13.1.
- (2) Turn on the power of all equipment.
- (3) Let the EUT work in test mode and 15 minutes before taking the test.

13.5. Test Procedure

- (1) For line to line coupling mode, provide a 1.0kV 1.2/50us voltage surge (at open-circuit condition) and 8/20us current surge to EUT selected points.
- (2) At least 5 positive and 5 negative (polarity) tests with a maximum 1/min repetition rate are conducted during test.
- (3) Different phase angles are done individually.
- (4) Record the EUT operating situation during compliance test and decide the EUT immunity criterion for above each test.

13.6.Surge Test Results

EUT : Disposable electronic cigarette	Test Date : N/A
M/N : 77777	Temperature : N/A
Test Engineer : N/A	Humidity : N/A
Test Voltage : N/A	Pressure : N/A
Test Mode : N/A	
Test Results : N/A	
Note: Not applicable for equipment operated with PC, Battery, or Power Supply.	

14. INJECTED CURRENTS SUSCEPTIBILITY TEST

14.1. Block Diagram of Test Setup

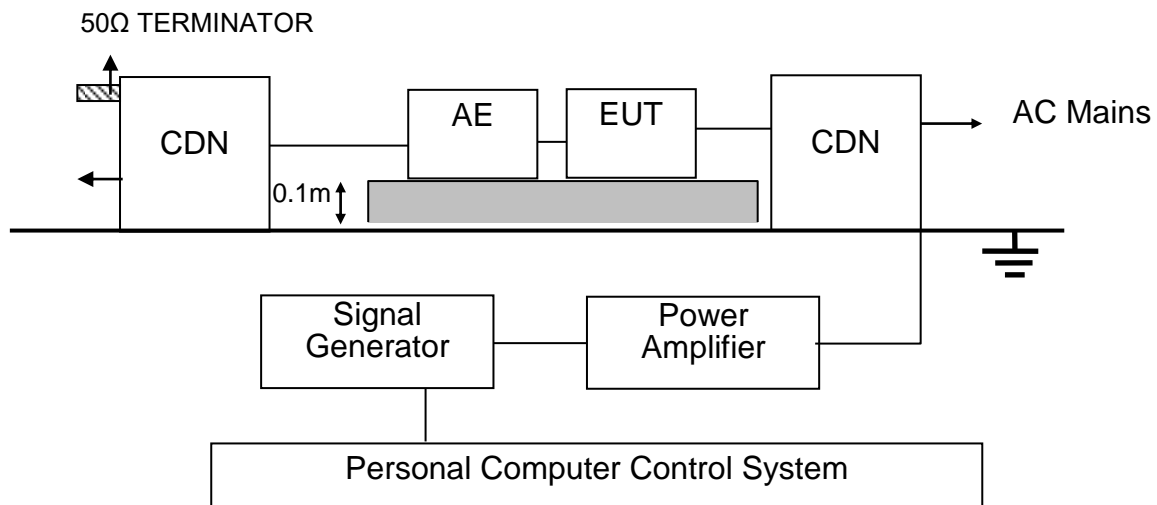

14.2. Test Standard

EN IEC 55014 -2: 2021

(Severity Level 2 at 3Vrms and frequency is from 0.15MHz to 230MHz)

14.3. Injected currents susceptibility Test Limits

Level	Voltage Level (e.m.f.) V
1	1
2	3
3	10
X	Special

- Notes:
1. Test set-up reference IEC 61000-4-6:2013
 2. Performance criterion: **A**

14.4. Configuration of EUT on Test

The following equipment are installed on Electrostatic Discharge Test to meet the IEC 61000-4-6 requirements and operating regulations in a manner that tends to maximize its emission characteristics in normal application.

14.5. Operating Condition of EUT

- (1) Setup the EUT as shown as Section 14.1.
- (2) Turn on the power of all equipment.
- (3) Let the EUT work in test mode and 15 minutes before taking the test.

14.6. Test Procedure

- (1) Let the EUT work in test mode and test it.
The EUT are placed on an insulating support 0.1m high above a ground reference plane. CDN (coupling and decoupling device) is placed on the ground plane about 0.3m from EUT. Cables between CDN and EUT are as short as possible, and their height above the ground reference plane shall be between 30 and 50 mm (where possible).
- (2) The disturbance signal described below is injected to EUT through CDN.
- (3) The EUT operates within its operational mode(s) under intended climatic conditions after power on.
- (4) The frequency range is swept from 0.150MHz to 230MHz using 3V signal level, and with the disturbance signal 80% amplitude modulated with a 1kHz sine wave.
- (5) The rate of sweep shall not exceed 1.5×10^{-3} decades/s. Where the frequency is swept incrementally, the step size shall not exceed 1% of the start and thereafter 1% of the preceding frequency value.
- (6) Recording the EUT operating situation during compliance testing and decide the EUT immunity criterion.
- (7)

14.7. Injected currents susceptibility Test Results

EUT	: Disposable electronic cigarette	Test Date	: N/A
M/N	: 77777	Temperature	: N/A
Test Engineer	: N/A	Humidity	: N/A
Test Voltage	: N/A	Pressure	: N/A
Test Mode	: N/A		
Test Results	: N/A		
Note: Not applicable for equipment operated with PC, Battery, or Power Supply.			

15. VOLTAGE DIPS AND INTERRUPTIONS TEST

15.1. Block Diagram of Test Setup

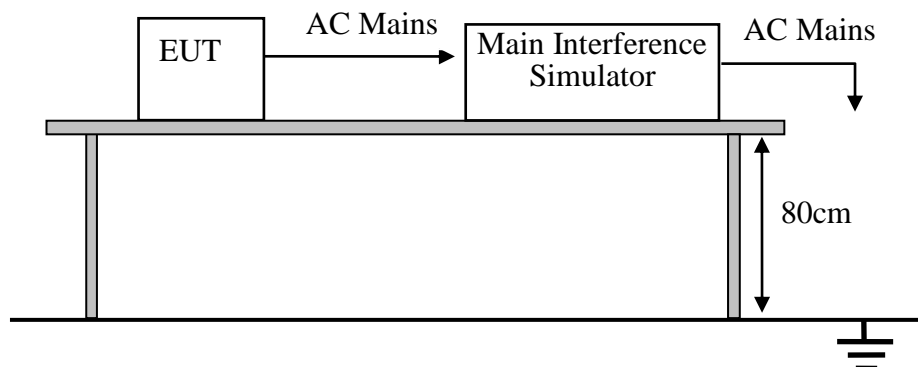

15.2. Test Standard

EN IEC 55014 -2: 2021

15.3. Voltage dips and interruptions Test Limits

Test Level %UT	Voltage dip and short interruptions %UT	Performance Criterion	Duration (in period)
0	100	C	0.5P
40	60	C	10P
70	30	C	25P

Notes: Test set-up reference IEC 61000-4-11:2020

15.4. Configuration of EUT on Test

The following equipment are installed on Electrostatic Discharge Test to meet the IEC 61000-4-11 requirements and operating regulations in a manner that tends to maximize its emission characteristics in normal application.

15.5. Operating Condition of EUT

- (1) Setup the EUT as shown as Section 15.1.
- (2) Turn on the power of all equipment.
- (3) Let the EUT work in test mode and 15 minutes before taking the test.

15.6. Test Procedure

- (1) The interruption is introduced at selected phase angles with specified duration.
- (2) Record any degradation of performance.

15.7.Voltage dips and interruptions Test Results

EUT	: Disposable electronic cigarette	Test Date	: N/A
M/N	: 77777	Temperature	: N/A
Test Engineer	: N/A	Humidity	: N/A
Test Voltage	: N/A	Pressure	: N/A
Test Mode	: N/A		
Test Results	: N/A		
Note: Not applicable for equipment operated with PC, Battery, or Power Supply.			

16. PHOTOGRAPH

16.1. Photo of Radiated Disturbance Test

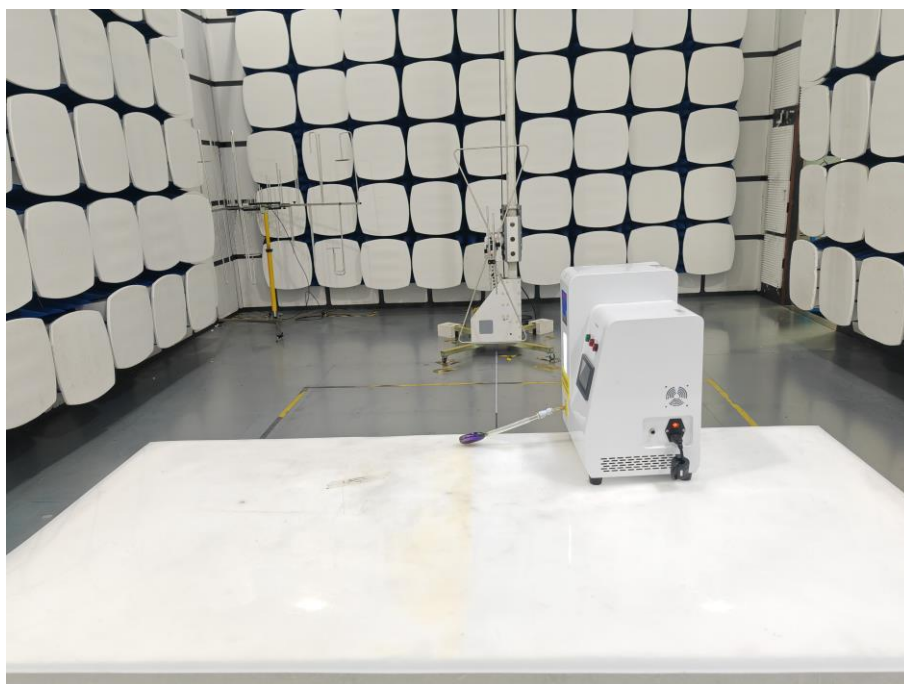

16.2. Photos Of Power Line Conducted Emission Test

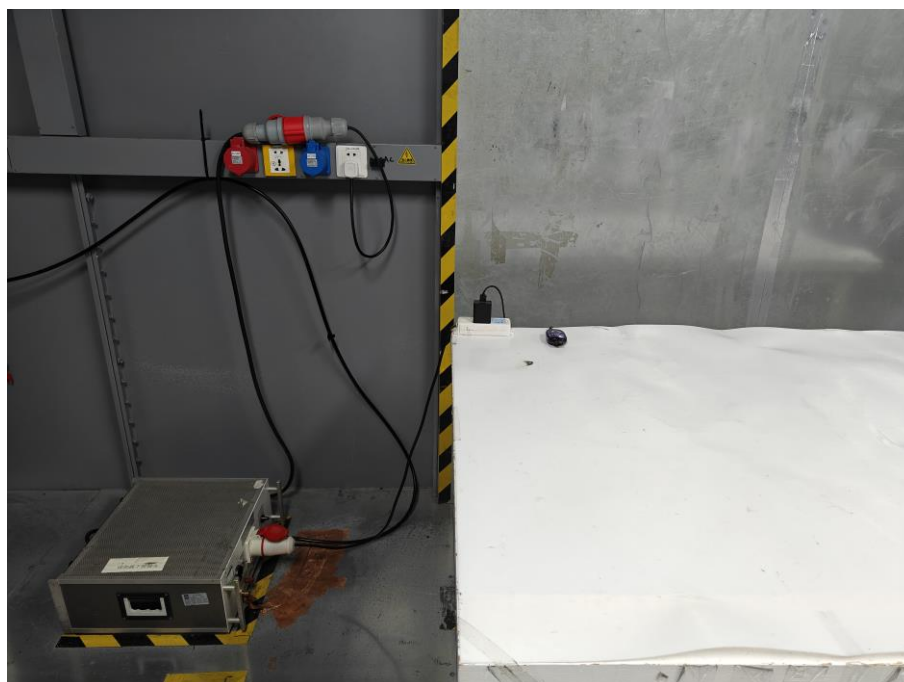

16.3.Photos of Electrostatic Discharge Test

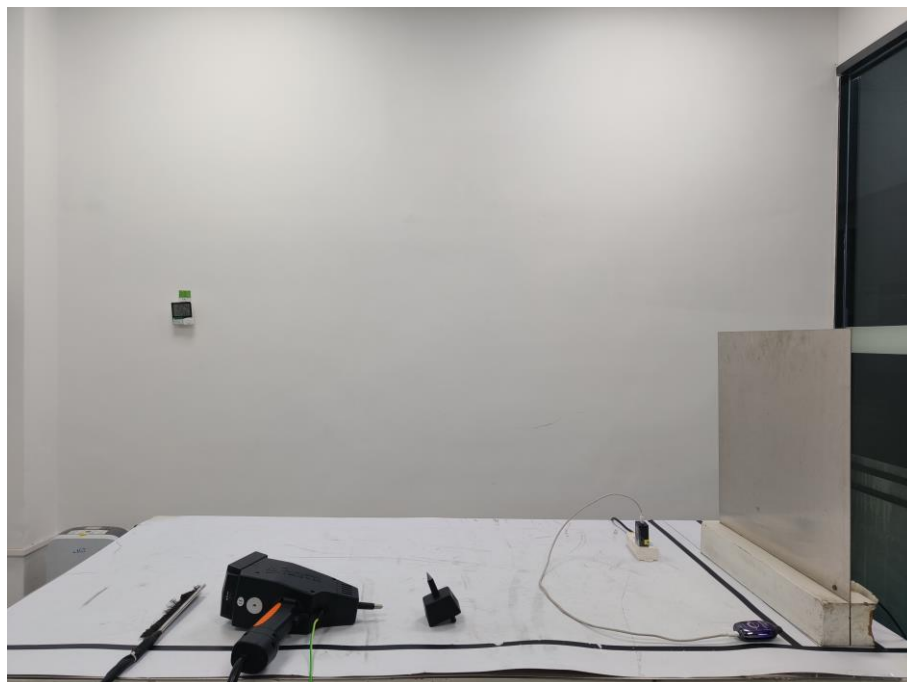

16.4.Photo of RF Field Strength Susceptibility Test

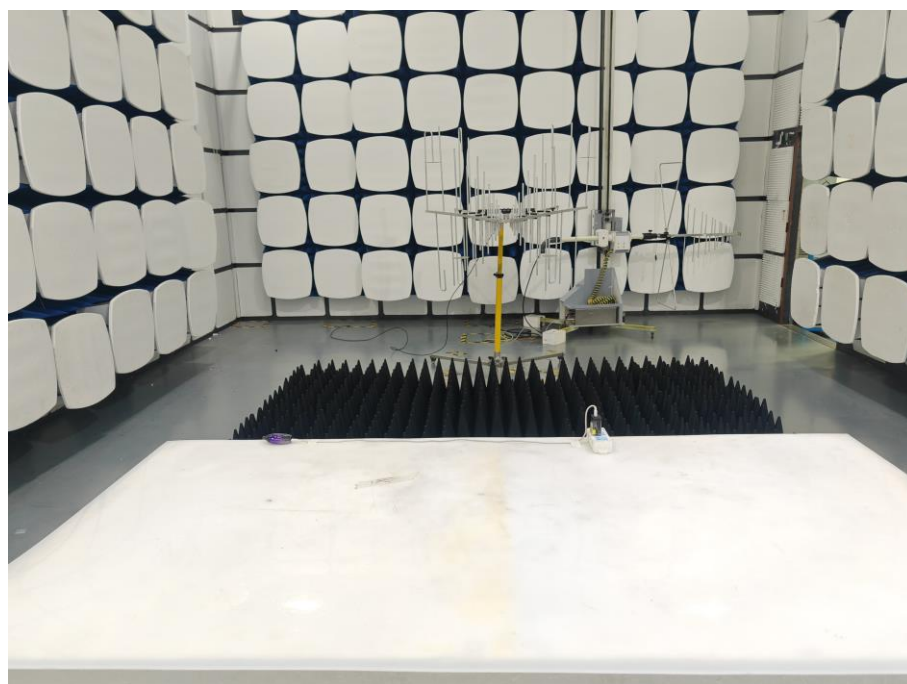

17. PHOTOS OF THE EUT

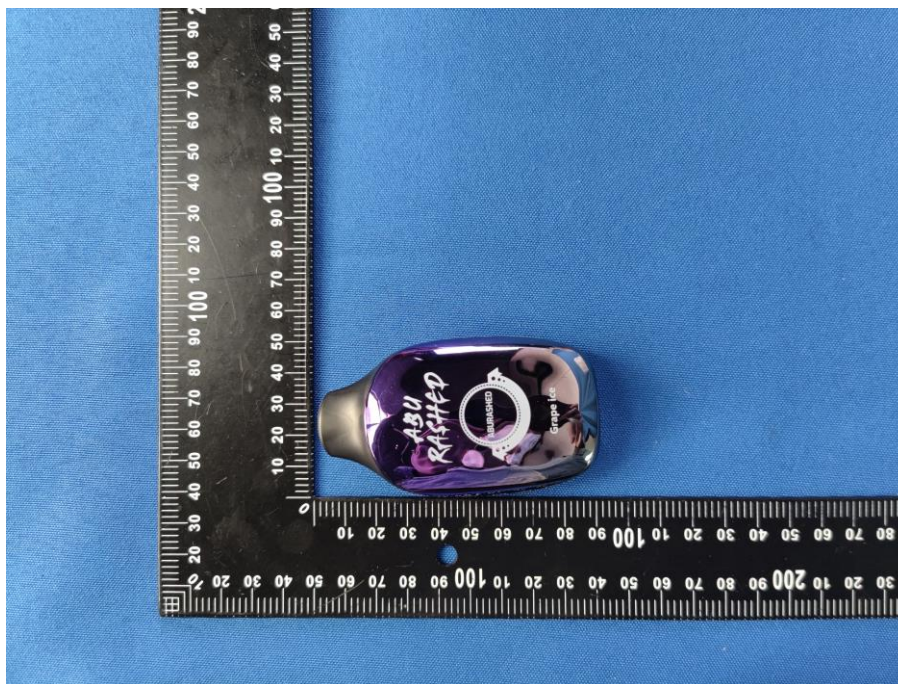

EUT View

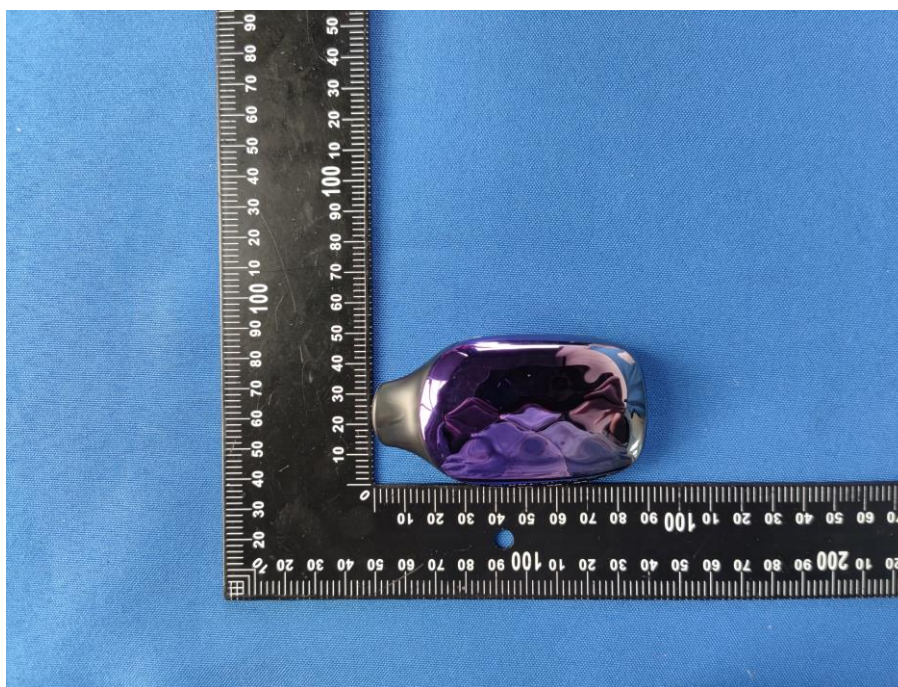

EUT View



EUT View

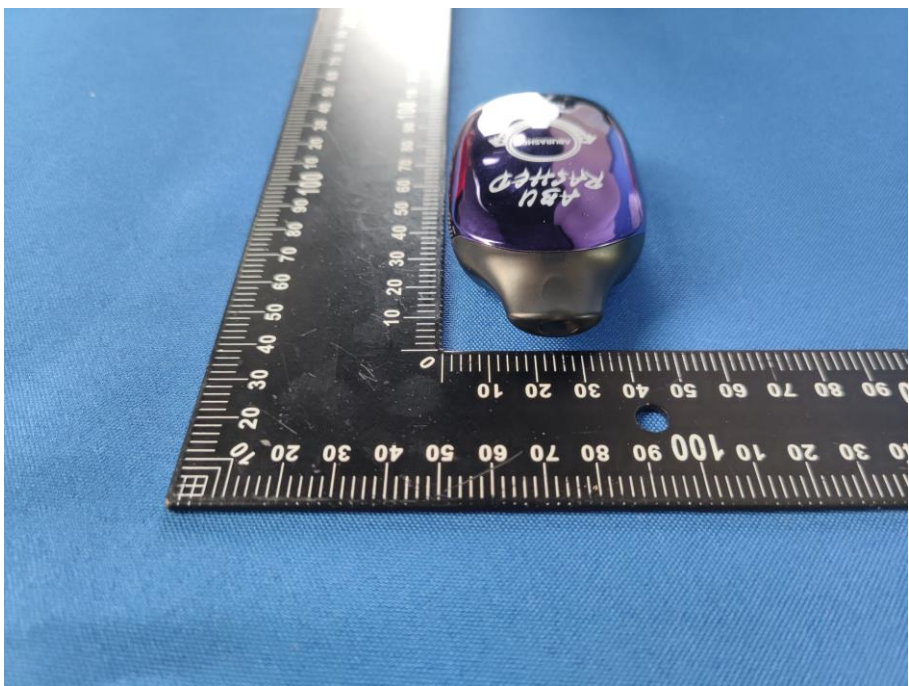

EUT View



EUT View

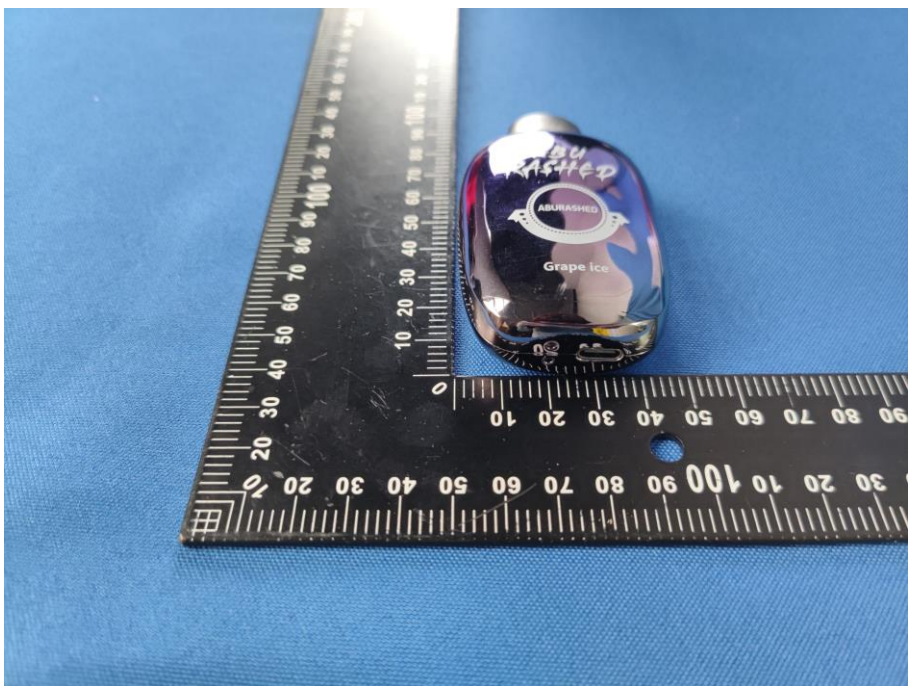

EUT View



EUT View



EUT View

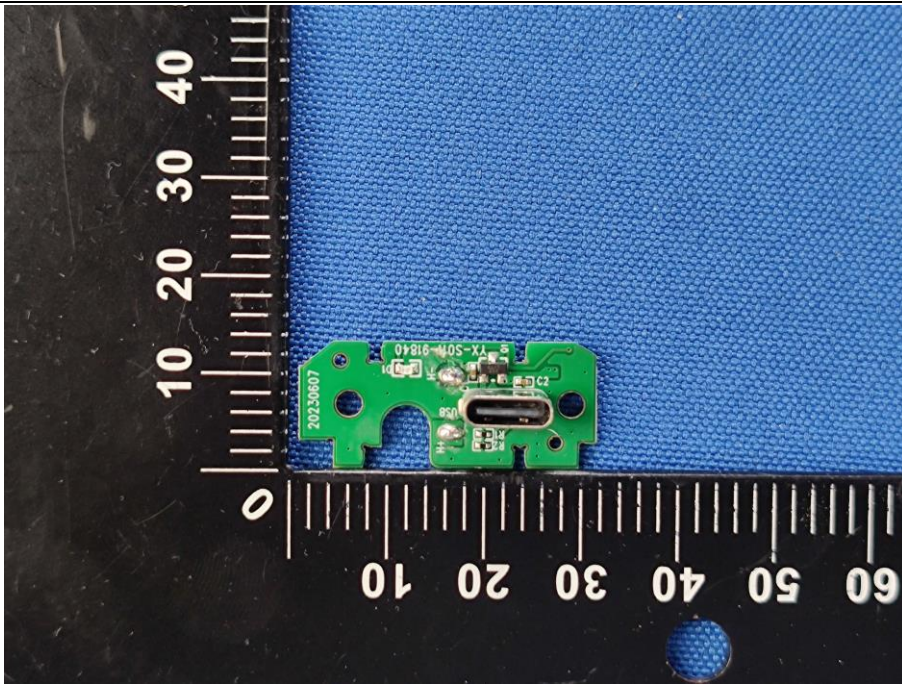

EUT View

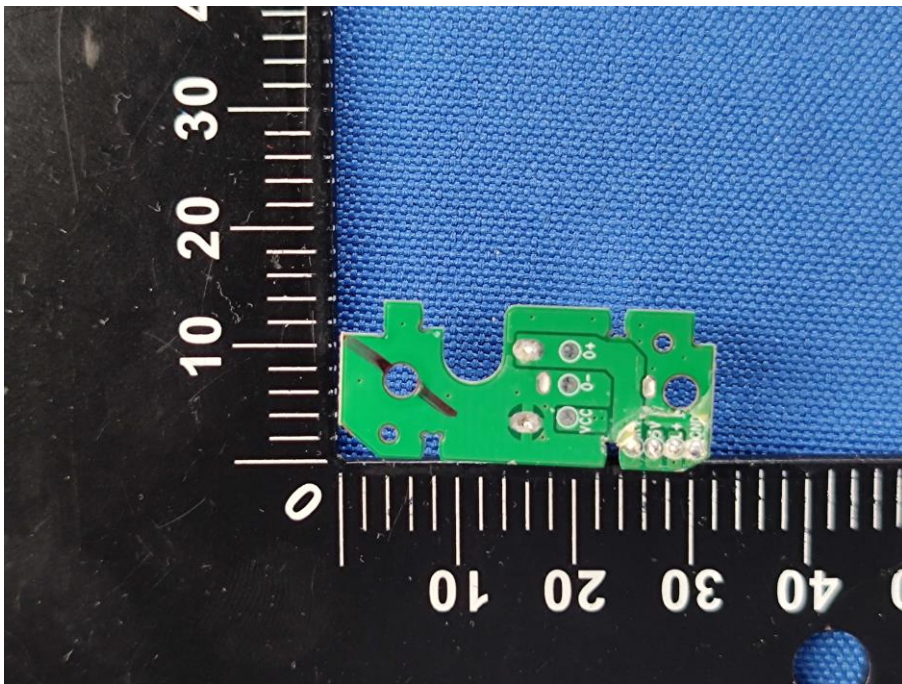

EUT View



EUT View

----END OF REPORT----